

CW3205VGBMDN2 Datasheet

iC LED Series (L* W*H): 3.2*0.5*1.0mm



Applications

- Telecommunication, office automation, home appliances, industrial equipment
- Full-color strip
- Consumer electronics
- Other applications

Features

- Serial data transmission signal by single wire.
- RGB and driver chip are integrated in a package, to form a complete control of pixel point with constant current.
- One pixel contains R, G, and B color that each can achieve 256 level brightness grayscale, which forms 16, 777, 216 combination colors. Internal clock frequency operates at 800 kHz.
- Lens color: White diffused
- RoHS2.0 and REACH-compliant
- ESD level 2kV(HBM)
- Preconditioning: accelerate to JEDEC level 3
- Typical view angle 50% Iv:140°

CW3205VGBMDN2

Dimensional Drawing

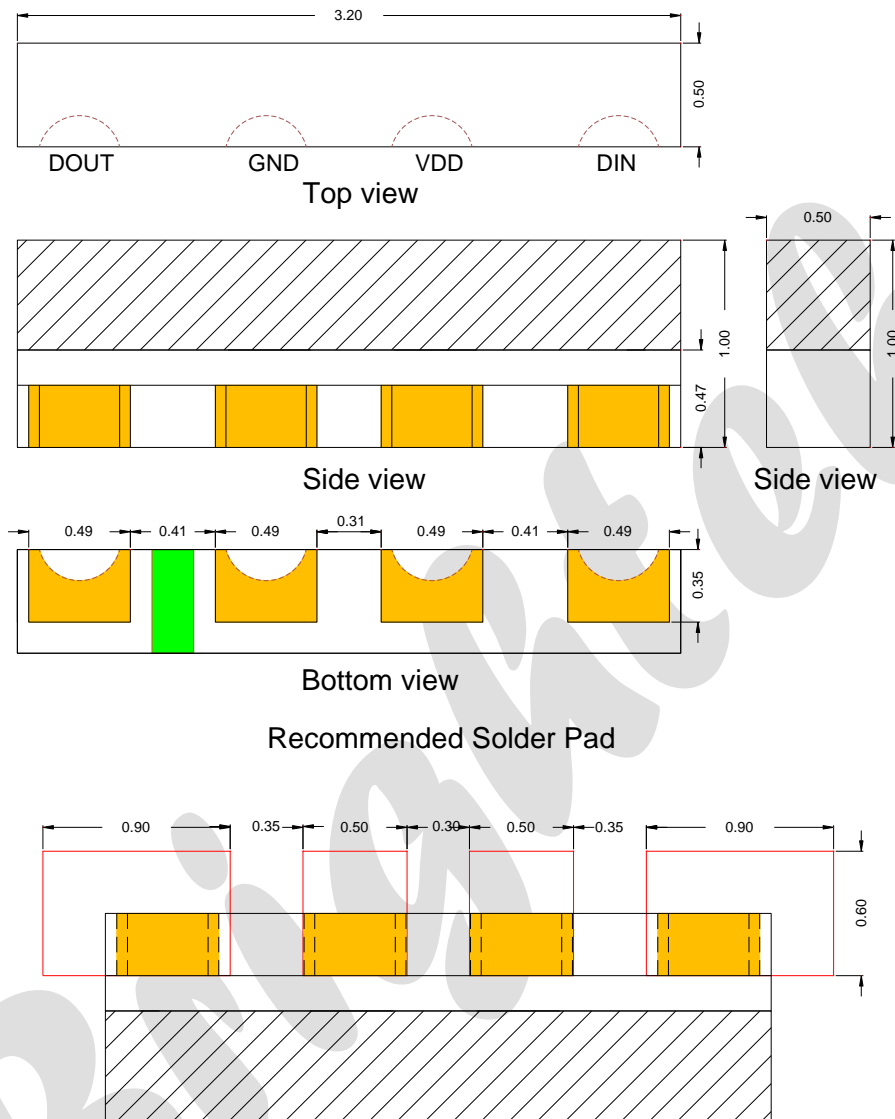

1. Dimensions are in millimeters.
2. General tolerance is ± 0.1 mm.

No.	Symbol	Function description
1	DIN	Control data signal input
2	VDD	Power supply LED
3	DOUT	Control data signal output
4	GND	Ground

CW3205VGBMDN2

Naming Rule

CW-3205-VGB-M-D-N2

CW	3205	VGB	M	D	N2
Type	Package Size	Color	Lens color	Output current	Serial number
CW: With IC Series	3205: 3.2*0.5mm	V:red G:green B:blue	M:White diffused	D:11.5mA	N2:Serial number

Maximum Ratings

T_A : 25 °C

Parameter	Symbol	Values	Unit
Forward current	I _F	11.5	mA
IC Power Supply Voltage	VDD	+3.8~+5.5	V
IC Input Voltage	V _I	-0.4~VDD+0.4	V
Operating Temperature Range	/	-40°C to +85	°C
Storage Temperature Range	/	-40°C to +105	°C
Soldering temperature	T _{SD}	260	°C

1. The maximum of soldering time is 10 seconds in T_{SD}.

CW3205VGBMDN2

Characteristics

VDD:5V | T_A : 25 °C

Characteristics	Symbol	Min.	Typ.	Max.	Unit	Test condition	
Luminous Intensity	I _v	R	125	208	320	mcd	VDD=5V
		G	250	460	800		
		B	50	85	160		
		W	400	700	1250		
Dominant Wavelength	λ _d	R	615	-	630	nm	VDD=5V
		G	520	-	535		
		B	460	-	475		
Color Coordinate	x	-	0.2724	-	-	VDD=5V	
	y	-	0.2836	-	-		
View Angle	2θ _{1/2}	-	140	-	-	VDD=5V	

1. Luminous intensity is measured with a light sensor and filter combination that approximates the CIE eye-response curve.
2. 2θ_{1/2} is the off-axis angle at which the luminous intensity is half the axial luminous intensity.
3. The dominant wavelength, λ_d is derived from CIE chromaticity diagram and represents the single wavelength which defines the color of the device. Peak Emission Wavelength Tolerance is ±1nm.

Bin groups

1. Luminous Intensity-White

VDD:5V | I_F : 11.5mA*3

Bin Code	Min. I _V (mcd)	Max. I _V (mcd)
18	400	500
19	500	630
20	630	800
21	800	1000
22	1000	1250

CW3205VGBMDN2

2. Chromaticity Coordinate Groups

VDD:5V | IF : 11.5mA*3

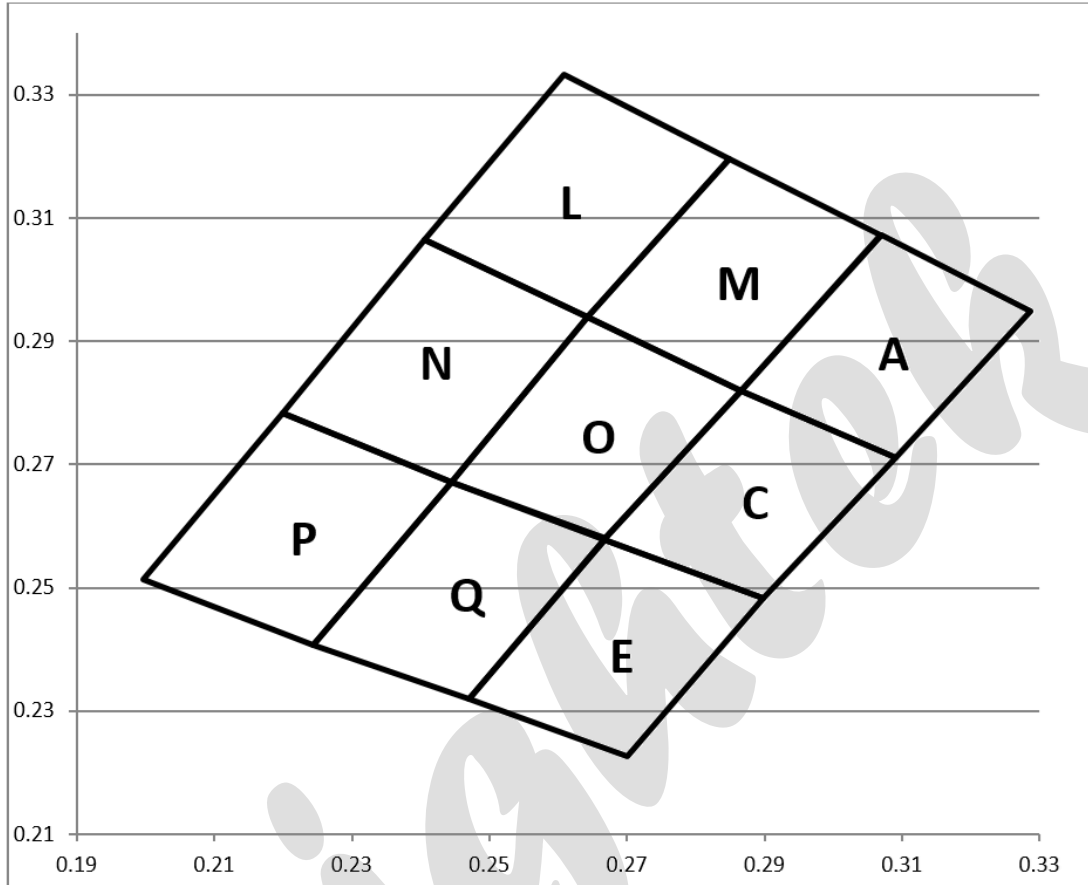

Bin	X	Y	X	Y	X	Y	X	Y
L	0.2406	0.3064	0.2609	0.3332	0.2849	0.3196	0.2643	0.294
N	0.22	0.2783	0.2406	0.3064	0.2643	0.294	0.2444	0.2672
P	0.22	0.2783	0.1996	0.2513	0.2244	0.2407	0.2444	0.2672
M	0.2643	0.294	0.2849	0.3196	0.3068	0.3072	0.2865	0.2819
O	0.2444	0.2672	0.2643	0.294	0.2865	0.2819	0.2667	0.2578
Q	0.2444	0.2672	0.2244	0.2407	0.2471	0.232	0.2669	0.2579
A	0.307	0.3072	0.3287	0.2948	0.3091	0.2712	0.2865	0.2819
C	0.2865	0.2819	0.3091	0.2712	0.2899	0.2482	0.2667	0.2578
E	0.2667	0.2578	0.2899	0.2482	0.27	0.2227	0.247	0.232

Tolerance of X/Y : ± 0.005

CW3205VGBMDN2

Electrical Characteristics

T_A : 25 °C

Characteristics	Symbol	Condition	Min.	Typ.	Max.	Unit
Standby current	I _{STB}	V _{DD} =4.5V, I _{out} = "OFF" "	-	0.5		mA
Input voltage level	V _{IH}	D _{IN} , Input high level voltage	3.1	-	-	V
	V _{IL}	D _{IN} , Input low level voltage	-	-	1.5	V

Switching Characteristics

T_A : 25 °C

Characteristics	Symbol	Condition	Min.	Typ.	Max.	Unit
Rate of data signal	F _{DIN}	-	-	800	-	kHz
Transfer time	T _{PLH}	D _{IN} →D _{OUT} D _{OUT} port to GND	-	-	80	ns
	T _{PHL}	CL=30pF	-	-	80	ns
Conversion time of IOUT R/G/B	T _R	I _{OUT} R/G/B =11.5mA	-	500	-	ns
	T _F	R _L =200Ω, CL=30pF	-	500	-	ns

Data transfer time

1. Timing Wave Form

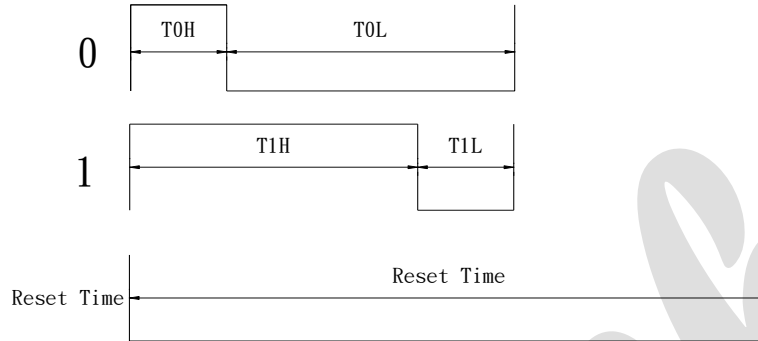

2. Data transfer time

Item	Description	Typical	Allowance
T_{0H}	0 code, high voltage time	0.3 μ s	$\pm 0.05\mu$ s
T_{0L}	0 code, low voltage time	0.9 μ s	$\pm 0.05\mu$ s
T_{1H}	1 code, high voltage time	0.9 μ s	$\pm 0.05\mu$ s
T_{1L}	1 code, low voltage time	0.3 μ s	$\pm 0.05\mu$ s
RES	reset time	>200 μ s	-

3. Composition of 24 bit data

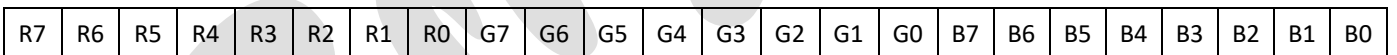

The single wire data transfer protocol supports 24-bit data for each LED's RGB display data refresh. ICLED receives 24-bit data and passes the remaining data to next ICLED. The 24-bit data consist of green, red and blue data, each with 8-bit width, and are transferred with MSB first

3.1 Data transmission method

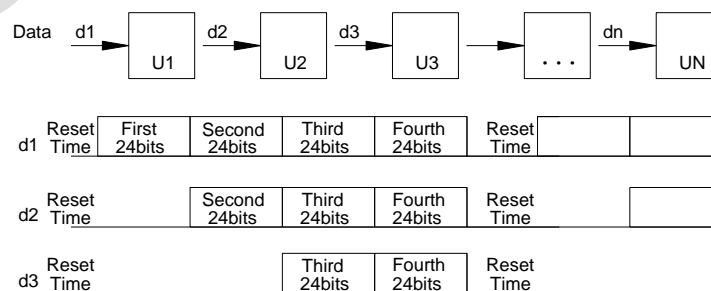

Reflow Soldering Profile

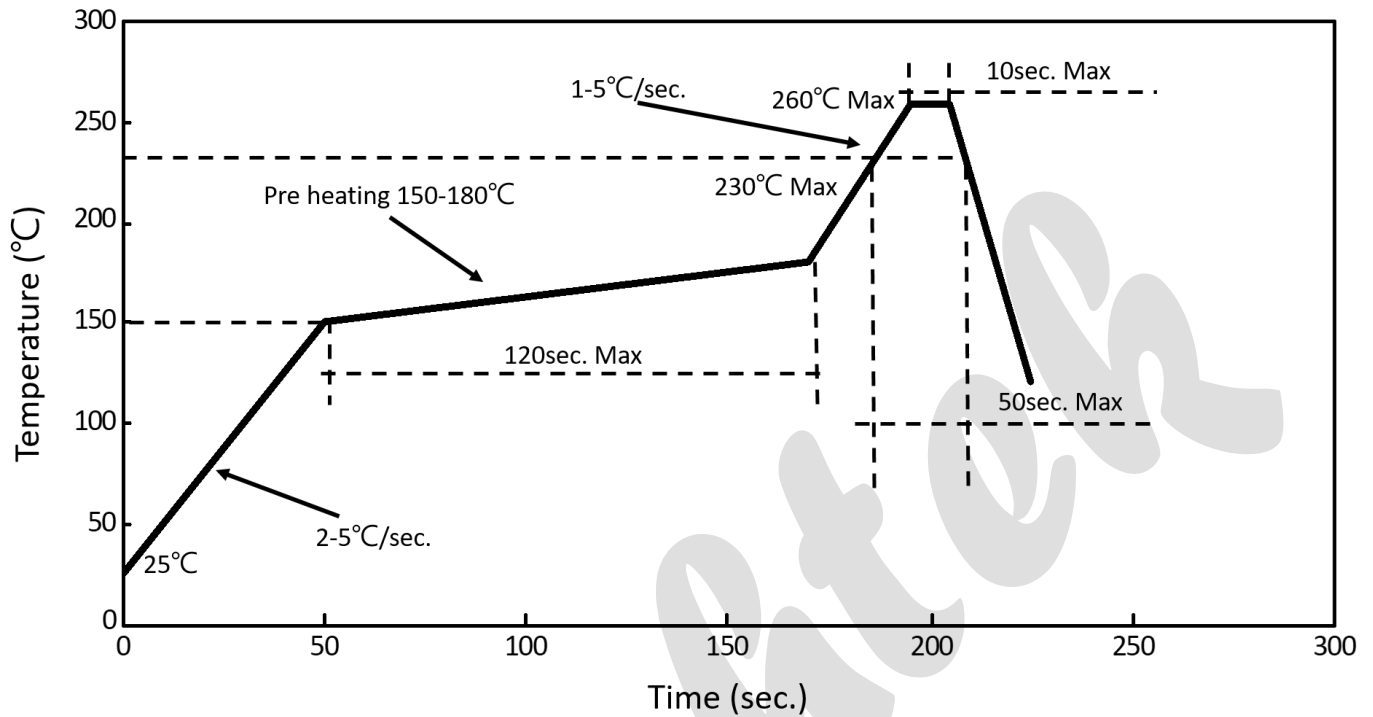

1. We recommend the reflow temperature 240°C ($\pm 5^\circ\text{C}$).the maximum soldering temperature should be limited to 260°C.
2. Do not stress the silicone resin while it is exposed to high temperature.
3. The reflow process should not exceed 3 times.

Test Circuit and Precautions for User

1. Typical application circuit

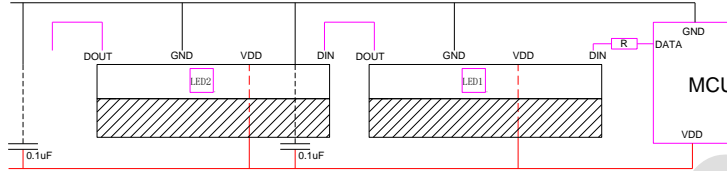

Notes:

When the first LED is connected to the MCU, a resistance R is needed in series between its signal input line and the MCU. The size of R depends on the number of cascade beads. The more cascades, the smaller resistance R is used. It is generally recommended that the value be between 100-1K. Usually the recommended value is around 300 R. In order to make the LEDs work more stably, a parallel capacitor is needed between VDD and GND of each LED.

In order to avoid harmful effects in use, please try to add resistance and capacitance when using. If capacitors and resistors are not added, the number of LEDs on the lamp should be minimized, but this way still does not exclude the risk of problems.

2. Handling precautions

2.1 Over-current-proof

Customer must apply resistors for protection; otherwise slight voltage shift will cause big current change (Burn out will happen).

2.2 Storage

① It is recommended to store the products in the following conditions:

- Humidity: 60% R.H. Max.
- Temperature : 5°C~30°C (41°F~86°F)

② Shelf life in sealed bag: 12 month at < 5°C~30°C and < 60% R.H. after the package is Opened, the products should be used within 1 weeks or they should be keeping to stored at $\leq 20\%R.H.$ with zip-lock sealed.

2.3 Baking

Suggest packing open after 1 weeks, before use baking products, conditions as follows:

- ① 60±3°C X 6hrs and < 5%RH, for reel
- ② 125±3°C X 2hrs, for single LED

It shall be normal to see slight color fading of carrier (light yellow) after baking in process.

CW3205VGBMDN2

Tapping

1. Dimensions of Tape (Unit: mm)

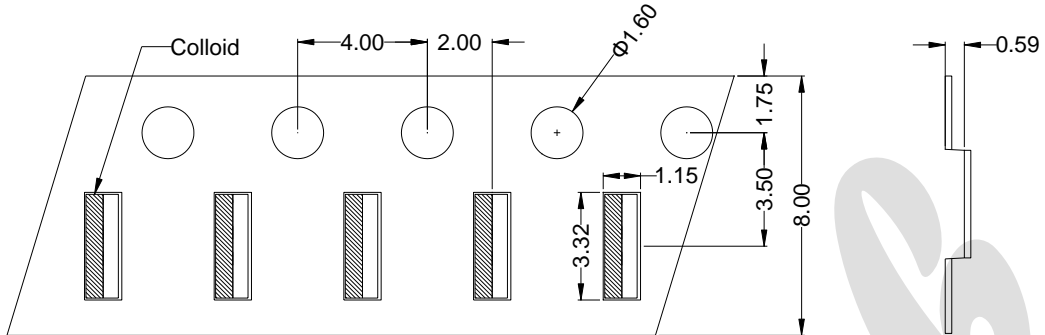

2. Arrangement of Tape

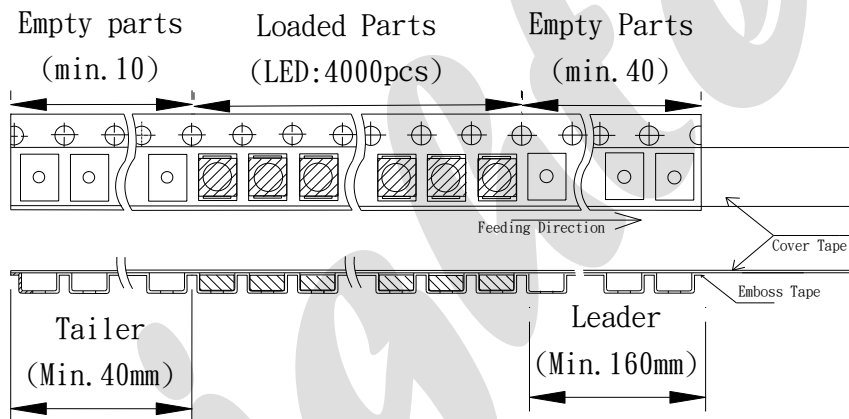

3. Dimensions of Reel (Unit: mm)

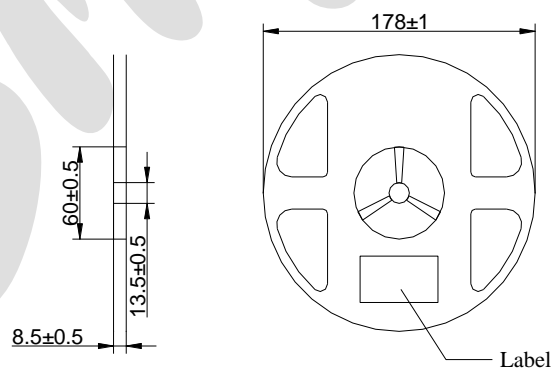

Notes:

1. Empty component pockets are sealed with top cover tape
2. The max loss number of SMD is 2pcs
3. The cathode is oriented towards the tape sprocket hole in accordance with ANSI/EIA RS-481 specifications
4. 4,000pcs per reel
5. The remainder packing in multiples of 500pcs.

Packing

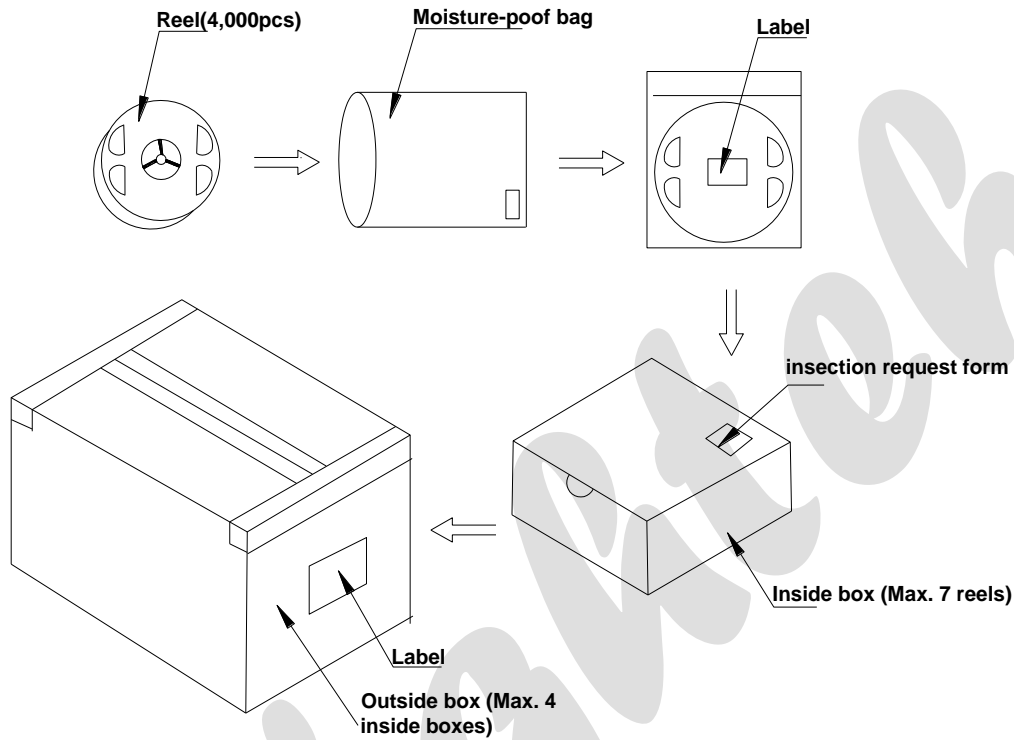

Reeled product (max.4,000) is packed in a sealed moisture-proof bag. Seven bags are packed in an inner box (size: about 260 X 230 X 100 mm) and four inner boxes are in an outer box (size: about 480 X 275 X 215 mm). On the label of moisture-proof bag, there should be the information of Part No., Lot No. and quantity number; also the total quantity number should be on inspection request form on outer box.

Precautions

1. Abnormal situation caused by improper setting of collet

To choose the right collet is the key issue in improving the product's quality. LED is different from other electronic components, which is not only about electrical output but also for optical output. This characteristic made LED more fragile in the process of SMT. If the collet's lowering down height is not well set, it will bring damage to the gold wire at the time of collet's picking up and loading which will cause the LED fail to light up, light up now and then or other quality problems.

2. How to choose the collet

During SMT, please choose the collet that has larger outer diameter than the lighting area of lens, in case that improper position of collet will damage the gold wire inside the LED. Different collets fit for different products, please refer to the following pictures cross out.

Outer diameter of collet should be larger than the lighting area

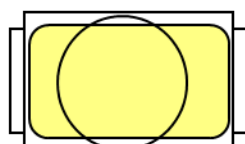

Picture 1 (✓)

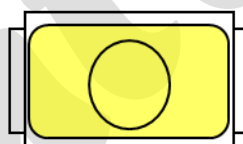

Picture 2 (X)

3. Other points for attention

- No pressure should be exerted to the epoxy shell of the SMD under high temperature.
- Do not scratch or wipe the lens since the lens and gold wire inside are rather fragile and cross out easy to break.
- CLED should be used as soon as possible when being taken out of the original package, and should be stored in anti-moisture and anti-ESD package.

4. This usage and handling instruction is only for your reference.

Disclaimer

1. Brightek reserves the right(s) on the adjustment of product material mix for the specification.
2. The product meets Brightek published specification for a period of one year from date of shipment.
3. The graphs shown in this datasheet are representing typical data only and do not show guaranteed values.
4. When using this product, please observe the absolute maximum ratings and the
5. instructions for using outlined in these specification sheets. Brightek assumes no responsibility for any damage resulting from the use of the product which does not comply with the absolute maximum ratings and the instructions included in these specification sheets.
6. These specification sheets include materials protected under copyright of Brightek. Reproduction in any form is prohibited without obtaining Brightek's prior consent.
7. This product is not intended to be used for military, aircraft, life sustaining or life saving applications or any other application which can result in human injury or death. Please contact authorized Brightek sales agent for special application request.